

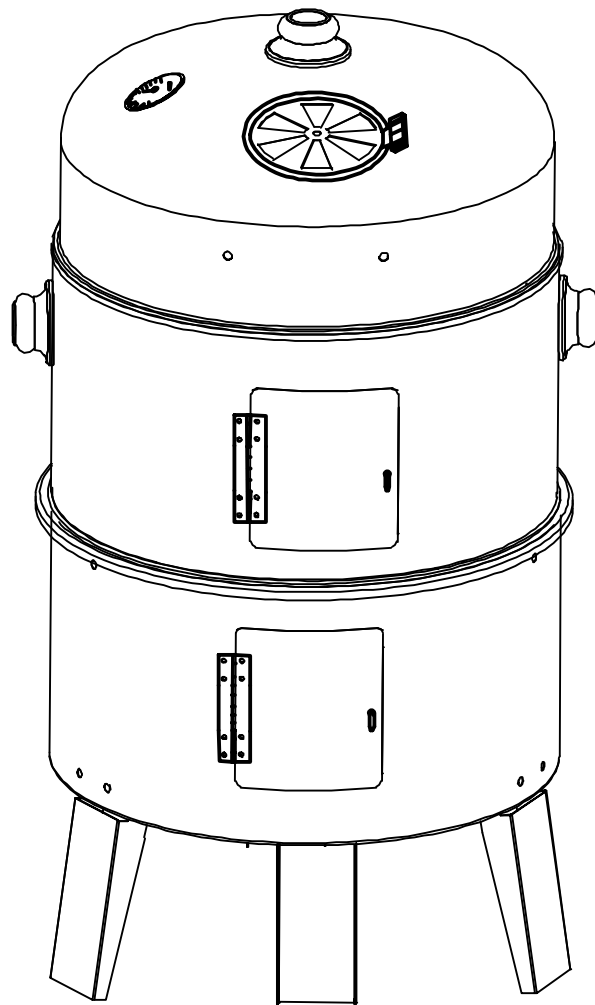

Portable Smoker USER MANUAL

Version: 1.2



**PLEASE READ AND UNDERSTAND THIS MANUAL
COMPLETELY BEFORE USING THE PRODUCT**

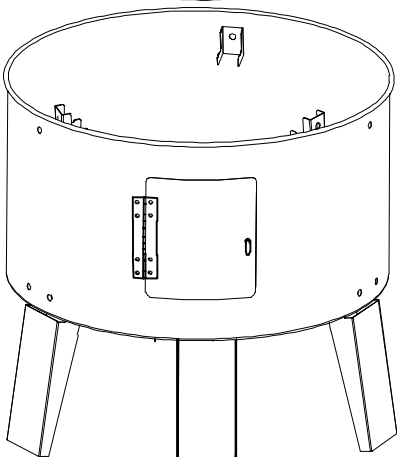
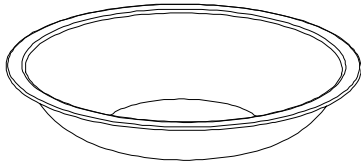
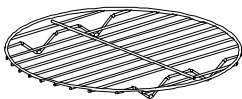
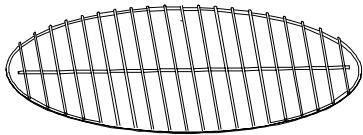
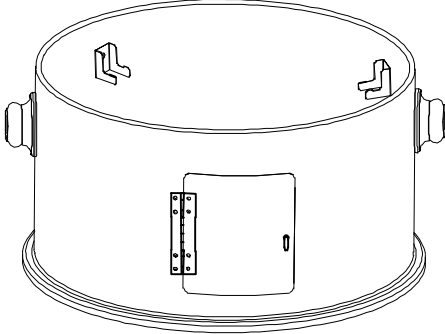
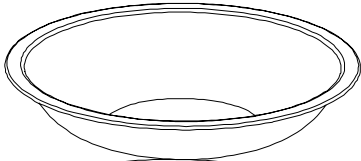
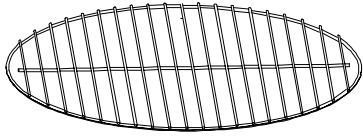
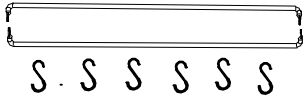
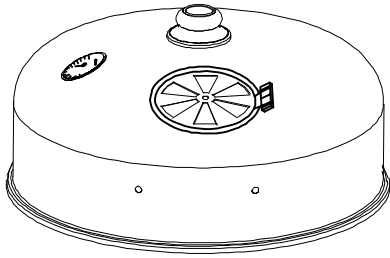

! WARNINGS &

SAFETY INFORMATION

- Body, lid and access doors will get hot during use.
- Ensure to use appropriate safety precautions to prevent burns.
- For outdoor use only. Do not operate indoors or in enclosed areas.
- Only use on solid, level ground.
- Keep away from combustible materials.
- Do not leave the smoker unattended.
- Keep away from children and animals.
- Do not move the smoker when active.
- Using abrasive cleaners or sharp objects can cause damage to the smoker's coating.
- Take care when adding additional fuel to the smoker.
- Extinguish the fuel source completely before leaving the smoker unattended.
- Only for use with solid fuels, do not use gas or liquid fuels.

SUITABLE FUELS

- Heat beads (ensure top vent is open).
- Timber
- Coals



12 MONTH LIMITED WARRANTY

WARRANTY PERIOD:

Full 12 month warranty from date of purchase against all manufacturing defects.

WHAT DOES THE WARRANTY COVER?

Under normal usage conditions, this warranty covers:

- a. Any defect in design or manufacture which results in the product failing to perform substantially as described in authorised advertising or literature.
- b. We will either repair or replace the product at our discretion providing that the fault is found to have been caused by a design or manufacturing defect and not misuse or tampering.

Our goods come with guarantees that cannot be excluded under the Australian Consumer Law. You are entitled to a replacement or refund for a major failure and for compensation for any other reasonably foreseeable loss or damage. You are also entitled to have the goods repaired or replaced if the goods fail to be of acceptable quality and the failure does not amount to a major failure. The benefits provided to you as the consumer by this warranty are in addition to other rights and remedies available to you under the law.

THE WARRANTY DOES NOT COVER:

- a. Any damage resulting from improper use
 - b. Faulty installation or modification made during installation
 - c. The cost of removing and reinstalling the product
 - d. Travel and /or other expenses due to customer's remote location
 - e. Transport charges and damage in transit. It is your responsibility to deliver and pick up your product, including any costs associated with the postage of your repair or replacement product. If you do freight your product we recommend that you insure against loss or damage.
 - f. Any loss directly or indirectly associated with the product failing to operate.
 - g. Damage caused by mould, insects, animals, misuse, incorrect operation, adverse weather, accidents and fair wear and tear
-

TO MAKE A CLAIM, PLEASE ENSURE YOU RETAIN YOUR SALES RECEIPT OF PURCHASE

CALL 1800 88 39 64



OUTDOOR SUPACENTRE PTY LTD
2 Stanley St Silverwater NSW, 2128
PHONE: 1800 88 39 64
www.4wdsupacentre.com.au